

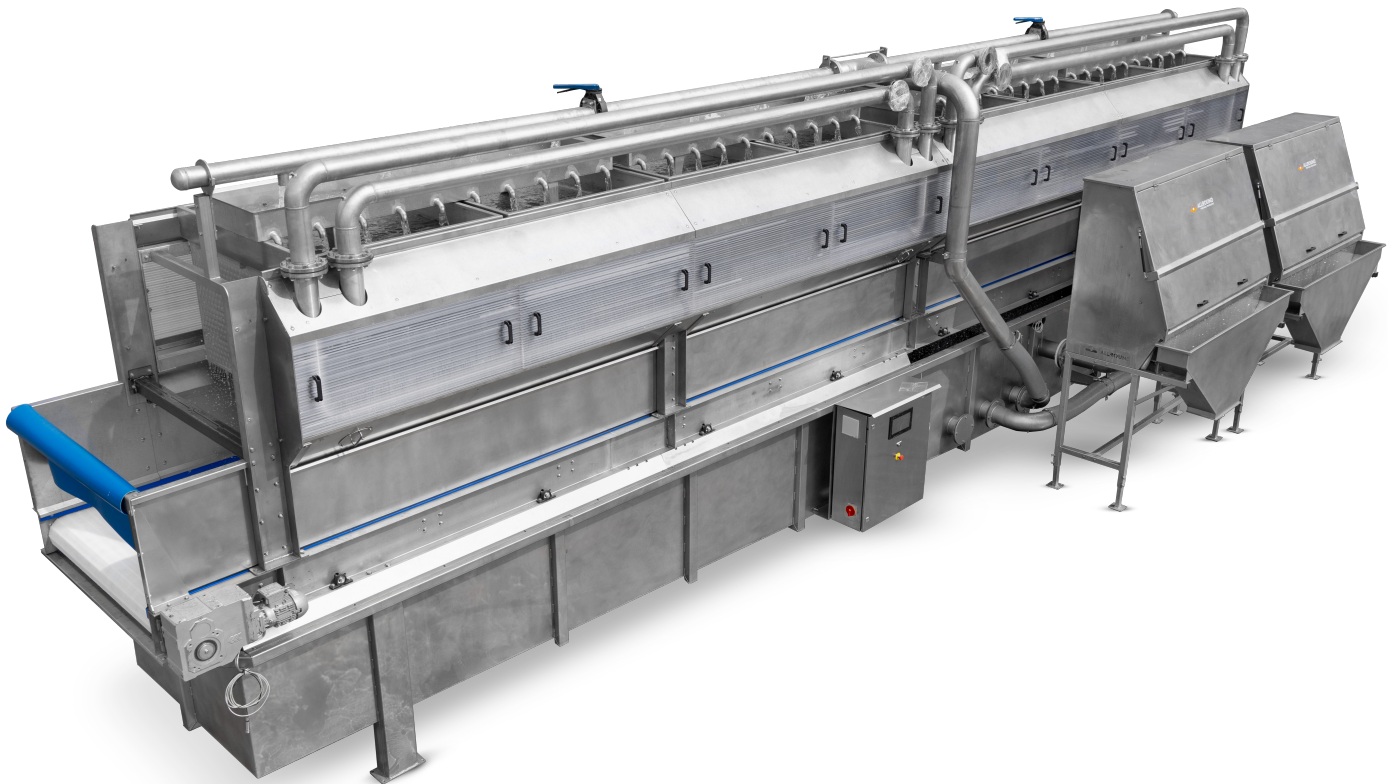

## HYDRO COOLER HC

The Allround hydrocooler is designed to extend the shelf life of fresh produce and preserve its quality.



### General description

The Allround hydrocooler is designed to extend the shelf life of fresh produce, especially effective for carrots, and preserve its quality by rapidly cooling it down before storage or transportation. The machine showers the produce with a continuous film of cold water as it moves on an Intralox conveyor, ensuring fast and uniform cooling in a fully controlled manner.

The system operates with a water basin located beneath the machine, where water is collected and pumped back into a water distribution system above. From there, the water is evenly distributed across cooling plates, creating a cold water shower that cools the produce in a fully controlled manner. Organic particles are removed from the water and pumped back to the water basin. Infrared temperature sensors at both the infeed and outfeed ends continuously monitor the cooling process. Water level sensors, valves for emptying tanks, and an inspection hatch make operation and maintenance simple.

For added flexibility, the hydrocooler can be designed with two lanes to handle different product grades simultaneously. With capacities ranging from small-scale to high-volume production, the Allround hydrocooler provides a reliable and energy-efficient solution for maintaining freshness and ensuring high-quality results in vegetable processing.

All dimensions in cm

		HC 50	HC 75	HC 100	HC 150	HC 200	HC 300
A	Capacity (in kW)	50	75	100	150	200	300
B	Cooling plates (in pieces)	15	20	30	45	60	80

All capacities are indications based on experience from the past and depend on the agro climatic, soil and logistic conditions of the product, Allround VP does not guarantee any of these.

## Characteristics

- ✓ Designed to extend the shelf life of fresh produce
- ✓ Stainless steel tank—strong and cleanable
- ✓ Cold-water shower for fast and uniform cooling
- ✓ Water distribution system with cooling plates
- ✓ Drain valves allow the tank to be drained of water. Both automatic and manual valves are available
- ✓ An optional two-lane design for handling multiple grades simultaneously
- ✓ Inspection hatch for simple maintenance and cleaning

## Options:

### ■ Material and treatment (frame)

Stainless steel      Frame is made from stainless steel AISI304. The bearings are from plastic and the drive/idle rollers are from stainless steel AISI304

### ■ Belt

Intralox flush grid 400      Passage of 17%  
The length of the belt is depends on the number of cooling plates

### ■ Electrical control

No electric      Motors and necessary sensors

Stand-alone      Motors, necessary sensors and control panel with HMI. The length of the cable is 5, 10, 15 or 20 meter

Central control in line      Motors and necessary sensors

### ■ Material and treatment (electrical plating)

Painted mild steel      The electrical panel is made from painted mild steel

Stainless steel      The plating is made from stainless steel AISI304

### ■ Support (electrical panel)

Mounted on machine      The electrical panel is mounted on the machine

Mounted on wall      The electrical panel is mounted on the wall. The length of the cable between the machine and the electrical panel is 5, 10, 15 or 20 meter

Subframe      The electrical panel is mounted on a subframe. The length of the cable between te machine and the electrical panel is 5, 10, 15 or 20 meter. The subframe is made from stainless steel AISI304, painted mild steel or galvanized steel

### ■ Drain valve

Manual      The valves can be operated manually

Automatic      The valves can be operated automatically

## Options:

### ■ Water management

Automatic                      The water level is regulated automatically

### ■ Cleats

Straight                      The type of cleats is straight

Turned                      The type of cleats is turned

### ■ Divider\*

Fixed lane                      A divider is mounted on the belt, to create 2 product flows. The divider is made from stainless steel AISI304

## HC 50

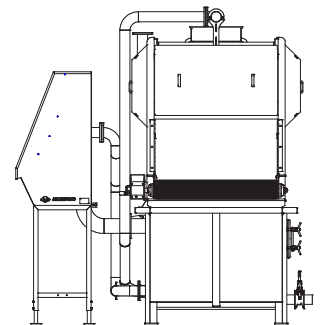
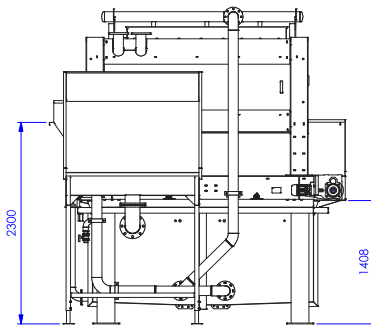
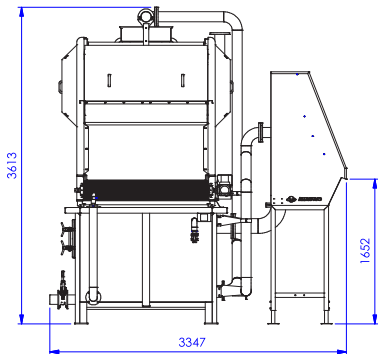
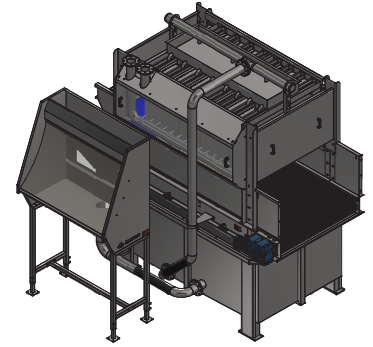
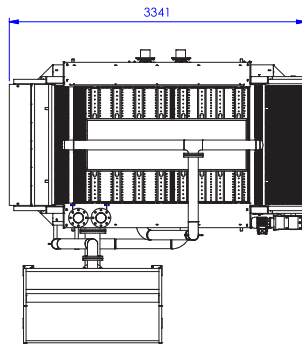
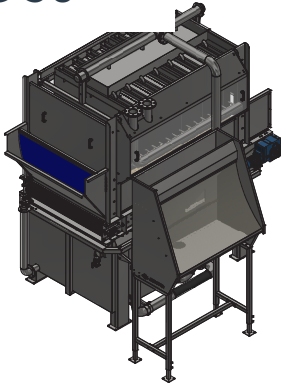

For discussion only!  
The dimensions are approximately.  
We are free to resize and change the machines,  
when we deem it necessary.

Tot principe: ISO 8015	General tolerances: ISO 2013	Fit system: ISO 286	Geometrical tolerancing: ISO 1101
Project: <b>Hydrocooler</b>			
Description: <b>HC 50</b>			
Surface: -			
Engineer: SRPL	Scale: 1:40	<b>00056022</b>	Revision: 00
Date: 13-8-2019	Sheet size: A3	Unit: mm	Sheet: 1 of 4

## HC 100

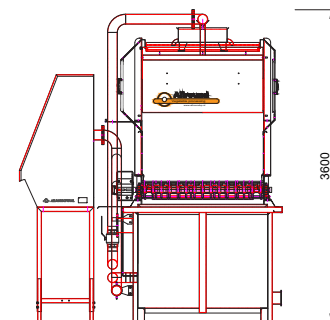
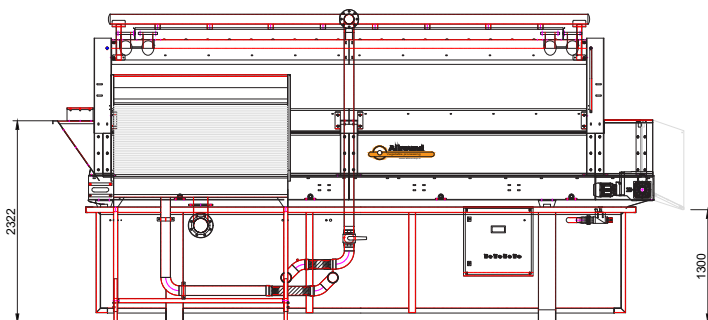
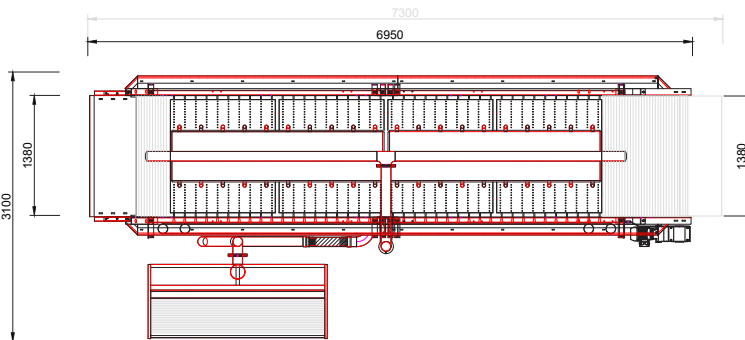

 <b>Allround</b> Vegetable processing www.allroundvp.nl	PROJECT: Hydrocooler HC 100		
	GETEKEND: DJA DATUM: 02-2015 SCHAAAL: 1:40 A3	TEK. NR: 00 VERSIE: 1.01	MATERIAAL: S235/AISI304 OPP. BEH: Coating KLEUR: RAL 7016/9006

# HC 150

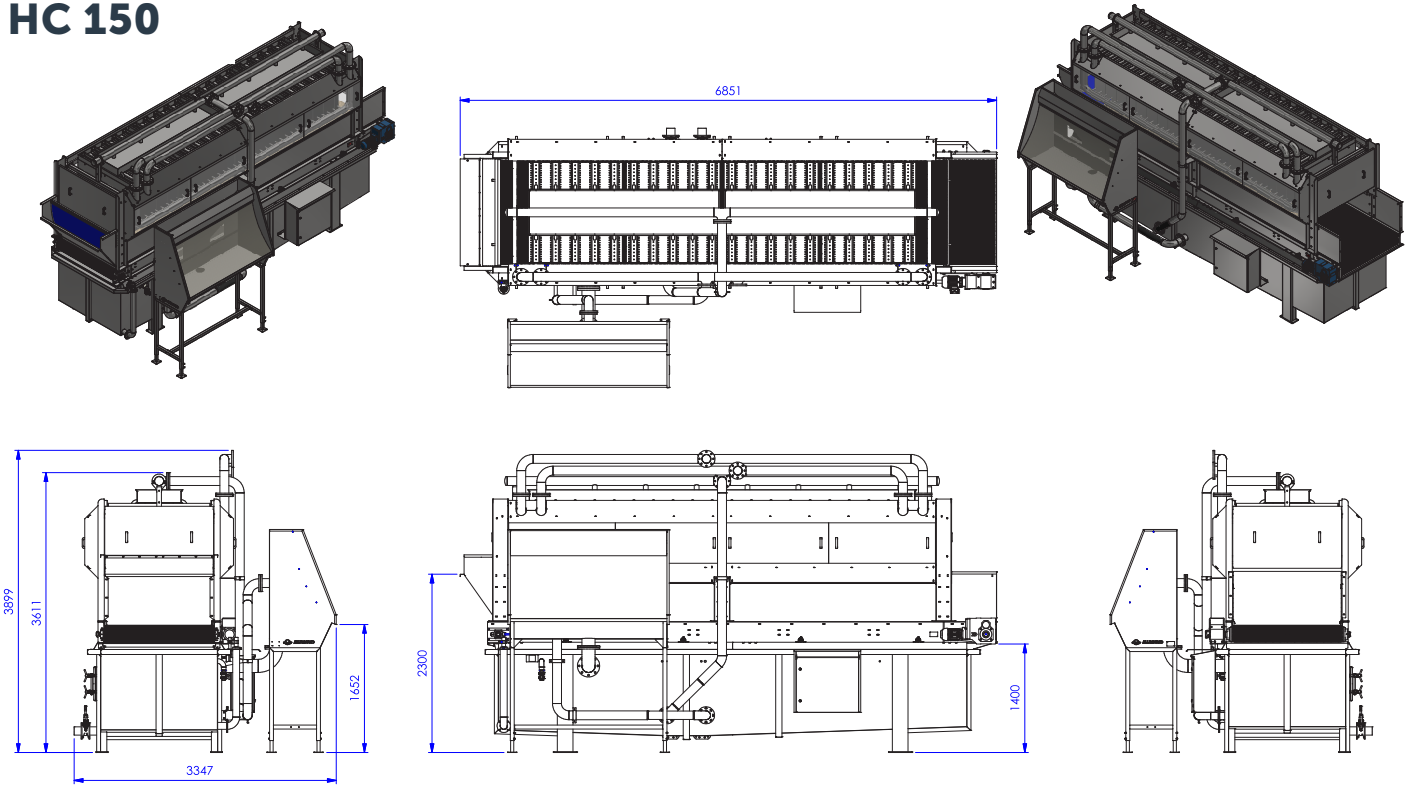

For discussion only!  
 The dimensions are approximately.  
 We are free to resize and change the machines,  
 when we deem it necessary.

Tot principe: SO 8015	General tolerances: ISO 2025	Fit system: ISO 286	Geometrical tolerancing: ISO 1101
Project: <b>Hydrocooler</b>			
Description: <b>HC 150</b>			
Surface: - - -			
Engineer: SRPL	Scale: 1 : 45	<b>0005244</b>	Revision:
Date: 12-7-2019	Sheet size: A3	mm	00
Unit:		Sheet: 1 of 4	

# HC 200

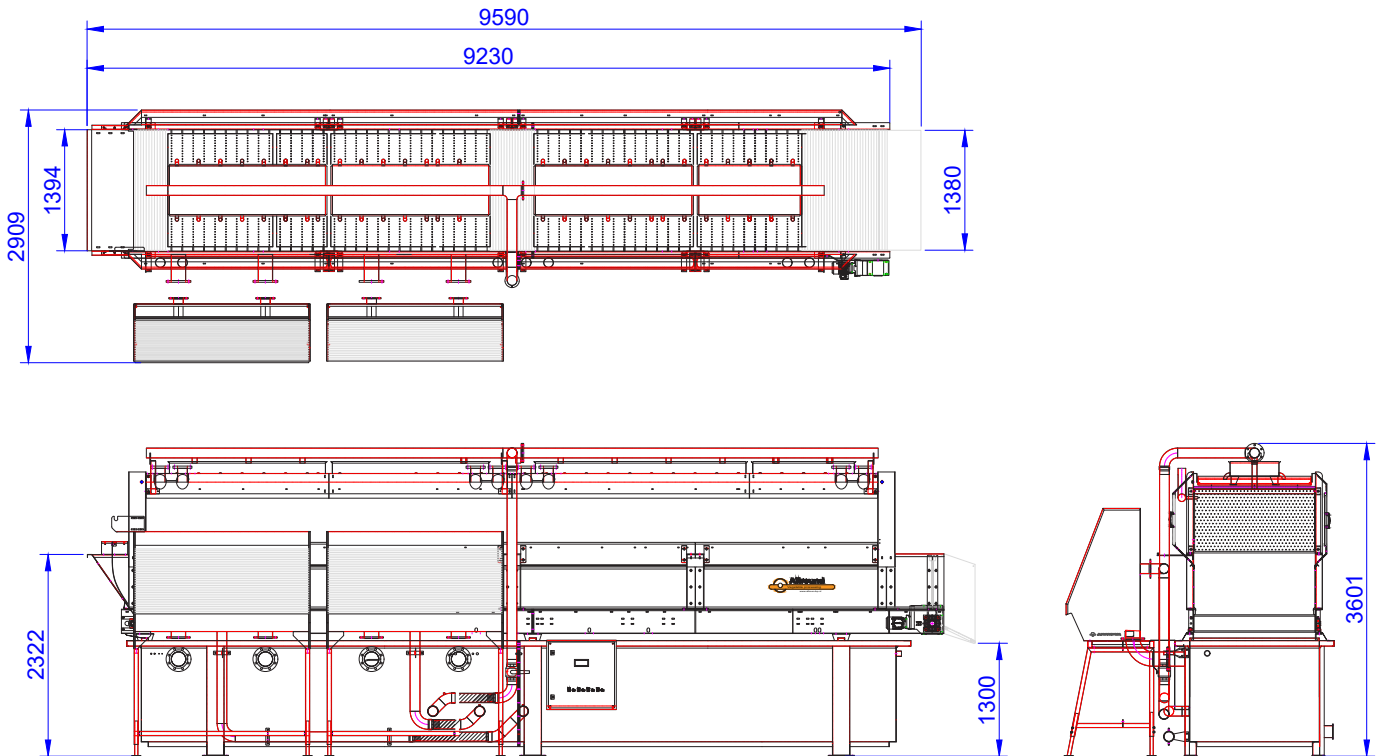

PO: 151	DESIGNED: HC200	MATERIAL: AFMETING	OPMERKING:
			
GETEKEND: HC200	PROJECT: Hydrocooler HC200	MATERIAL: AIS304	
DATE: 15-12-2019	TECH. NR: 00	OPM. NR: 00	
FORMAAT: A3 1:20	VERSIE: 1.01	TECH. NR: 00	

# HC 300

THIS SKETCH IS ONLY FOR DISCUSSION!  
FINAL LAYOUT FOR APPROVEMENT WILL BE  
SEND AFTER ORDER

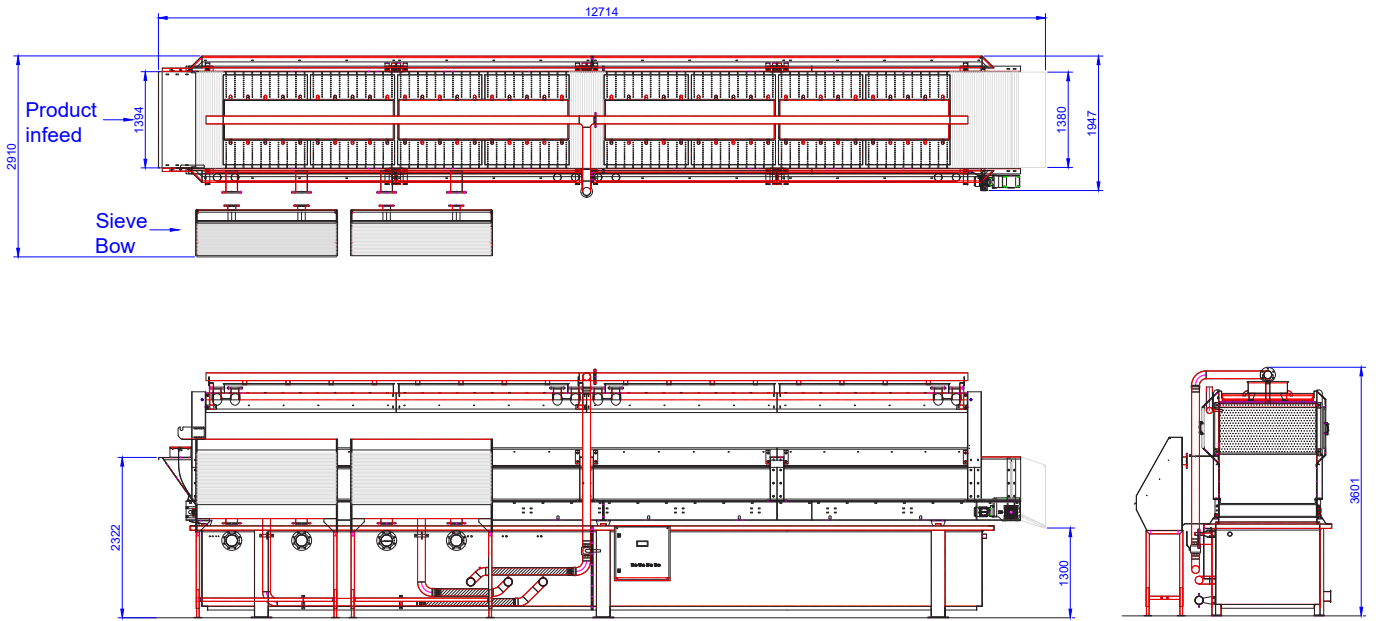

For discussion only!  
The dimensions are approximately.  
We are free to resize and change the machines,  
when we deem it necessary

	HC 300		
	Engineer: BD	Project: Standard	Product: PRODUCT
	Checked by:	Drawing Nr: 01	Capacity:
	Scale: 1:50 A3	Date: 07-2021	Box Size: