

LEAF SEPARATOR LSH

The leaf separator removes leaves, vines, sticks, roots, and loose dirt from produce flow. The produce is transported on a pindle belt towards powered sweep roller. The produce is transported on a pindle belt towards powered sweep roller.

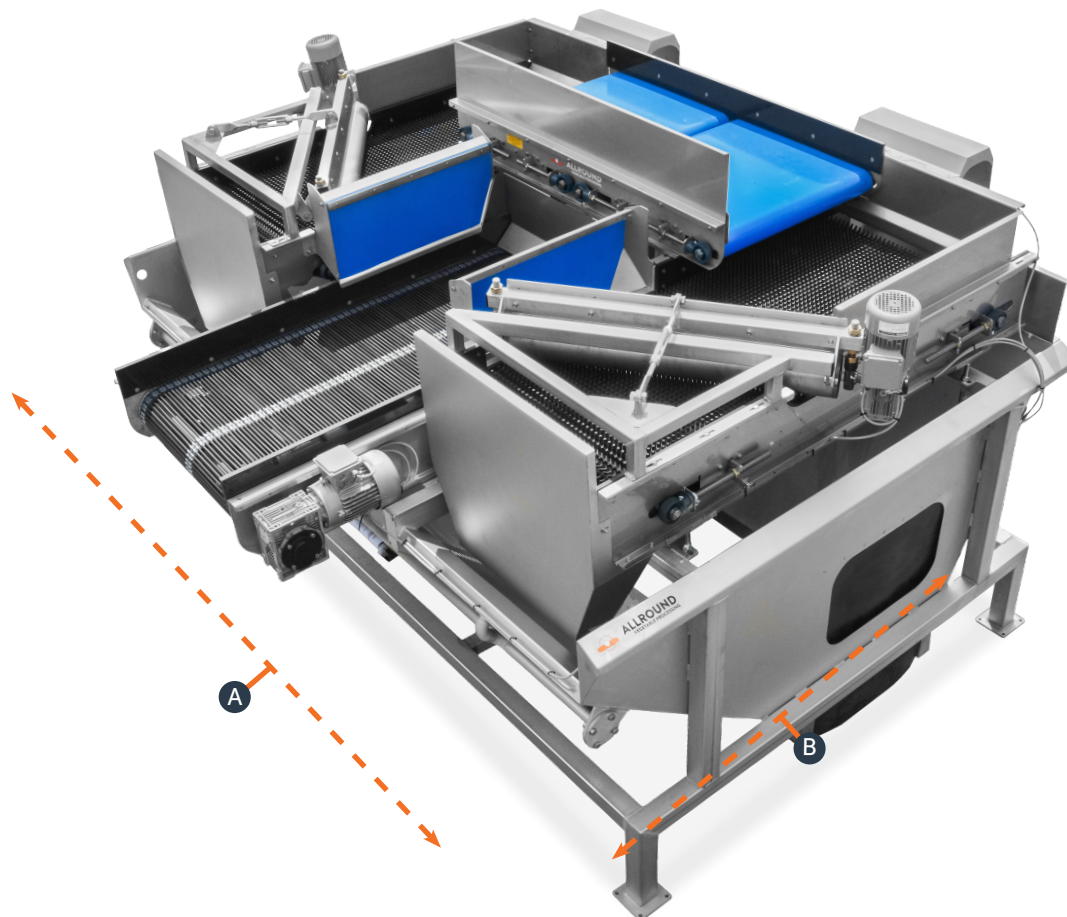

General description

The leaf separator removes leaves, vines, sticks, roots, and loose dirt from produce flow. The produce is transported on a pindle belt towards powered sweep roller. This powered sweep roller pushes the produce off the machine and debris are left behind on the belt. When the belt returns, the debris fall from the belt. You can adjust the gap between the powered sweep roller and the belt to control the size of the debris that will be removed from produce flow.

The standard machine is supplied with a frame made from painted mild steel, sides are made from zinc plated steel, and bearings and drive/idle rollers are of mild steel. On demand, the Frame and sides can be made from stainless steel AISI304 but bearings and drive/idle rollers are of mild steel. The hedgehog belt is made of rubber.

The standard machine is supplied with subframe is made of Painted mild steel. On demand, the subframe can also be made from stainless steel AISI304 and galvanized steel. The height of the subframe can vary from 0-7 meters.

All dimensions in cm

		LSH 150	LSH 200	LSH 250
A	Length of the machine	150	200	250
B	Width of the machine	80	80	80

All capacities are indications based on experience from the past and depend on the agro climatic, soil and logistic conditions of the product, Allround VP does not guarantee any of these.

Characteristics

- ✓ Available in 80, 200, and 250 cm width
- ✓ The hedgehog belt is made of rubber
- ✓ The height of the subframe can vary from 0-7 meters
- ✓ High quality pintle belt is long lasting and great for collecting debris
- ✓ Tensioner for easy tension adjustment. Very low maintenance.
- ✓ Compact, rugged design for a longer machine life

Options:

■ Material and treatment (frame)

Painted mild steel Frame is from painted mild steel. The sides are from zinc plated steel. The bearings and drive/idle rollers are from mild steel

Stainless steel Frame is from stainless steel AISI304. The sides are from stainless steel AISI304. The bearings and drive/idle rollers are from mild steel

■ Belt

Hedgehog rubber The hedgehog belt is made of rubber

■ Electrical control

No electric Motors and necessary sensors

Stand-alone Motors, necessary sensors and control panel

Central control in line Motors and necessary sensors

■ Material and treatment (electrical panel)

Painted mild steel The electrical panel is made from painted mild steel

Stainless steel The electrical panel is made from stainless steel AISI304

■ Material and treatment (subframe)

Painted mild steel It is made from painted mild steel

Stainless steel It is made from stainless steel AISI304

Galvanized steel It is made from galvanized steel







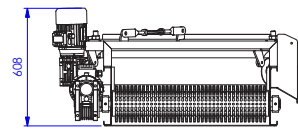
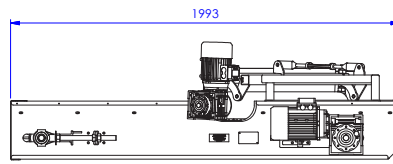
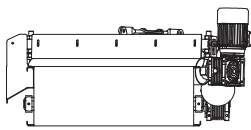
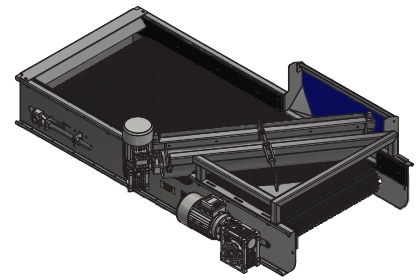
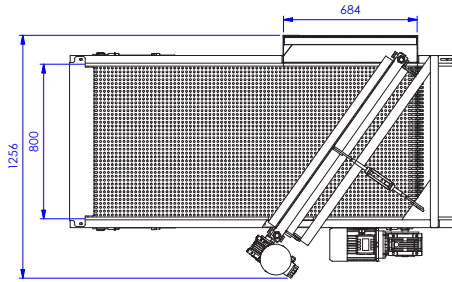
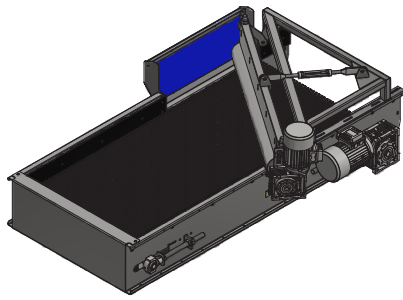





■ Height of subframe

Height of subframe 0 to 7 meter

LSH 200



For discussion only!
The dimensions are approximately.
We are free to resize and change the machines,
when we deem it necessary.

For principle: ISO 8015		General tolerances: ISO 20768		Fit system: ISO 284		Geometrical tolerancing: ISO 1101	
 Project: Leaf separator							
 Description: LSH 200-80 (L)							
 Surface:							
 Engineer: JAJ		 Scale: 1:18		 00043603		 Revision:	
 Date: 23-5-2019		 Sheet size: A3		 Unit: mm		 Sheet: 1 of 2	
 ALLROUND VEGETABLE PROCESSING <small>www.allround.nl</small>							