

LEAF SEPARATOR LS

The leaf separator removes leaves sticks, vines, roots, and loose dirt from produce flow efficiently.

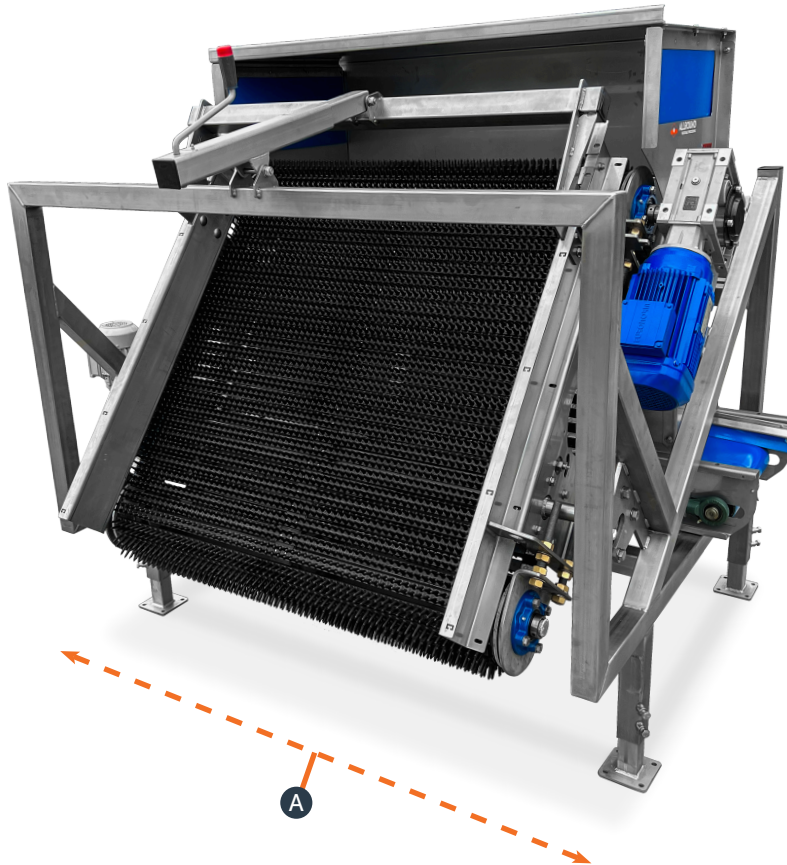

General description

The leaf separator removes leaves, sticks, vines, roots, and loose dirt from produce flow. The Produce is dropped and rolled down on a hedgehog belt, which is placed at an angle. While Produce rolls down and drops on a belt, debris is caught by belt pintle fingers and carried up to a waste chute or conveyor

Produce is discharged gently, either onto a conveyor or into a water body like a wet hopper or destoner machine, water flumes, minimizing falling impact.

The standard machine is supplied with a frame made from painted mild steel, sides are made from zinc plated steel, and bearings and drive/idle rollers are of mild steel. On demand, the Frame and sides can be made from stainless steel AISI304 but bearings and drive/idle rollers are of mild steel. The hedgehog belt is made of rubber.

The standard machine is supplied with subframe is made of Painted mild steel. On demand, the subframe can also be made from stainless steel AISI304 and galvanized steel. The height of the subframe can vary from 0-7 meters.

All dimensions in cm

		LS 80	LS 100	LS 120
A	Width of the machine	80	100	120

All capacities are indications based on experience from the past and depend on the agro climatic, soil and logistic conditions of the product, Allround VP does not guarantee any of these.

Characteristics

- ✓ Available in 80, 100, and 120 cm width
- ✓ The hedgehog belt is made of rubber
- ✓ Belt tensioner for easy tension adjustment
- ✓ Inspection hatch (both sides) which is helpful for belt removal and replacement
- ✓ The height of the subframe can vary from 0-7 meters
- ✓ Adjustable operation angle to suit different produce types or different amounts of carrot top being removed

Options:

■ Material and treatment (frame)

Painted mild steel	Frame is from painted mild steel. The sides are from zinc plated steel. The bearings and drive/idle rollers are from mild steel
Stainless steel	Frame is from stainless steel AISI304. The sides are from stainless steel AISI304. The bearings and drive/idle rollers are from mild steel

■ Belt

Hedgehog rubber	The hedgehog belt is made of rubber
-----------------	-------------------------------------

■ Electrical control

No electric	Motors and necessary sensors
Stand-alone	Motors, necessary sensors and control panel. The length of the cable is 5, 10, 15 or 20 meter
Central control in line	Motors and necessary sensors

■ Material and treatment (electrical panel)

Painted mild steel	The electrical panel is made from painted mild steel
Stainless steel	The electrical panel is made from stainless steel AISI304

■ Material and treatment (subframe)

Painted mild steel	It is made from painted mild steel
Stainless steel	It is made from stainless steel AISI304
Galvanized steel	It is made from galvanized steel

■ Height of subframe

Height of subframe	0 to 7 meter
--------------------	--------------

Options:

■ **Adjustment angle**

Manual

The angle can be adjusted manually

Automatic

The angle can be adjusted automatically

LS 80

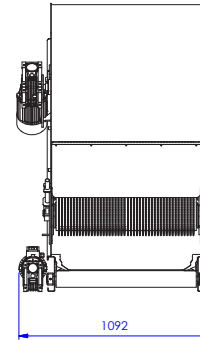
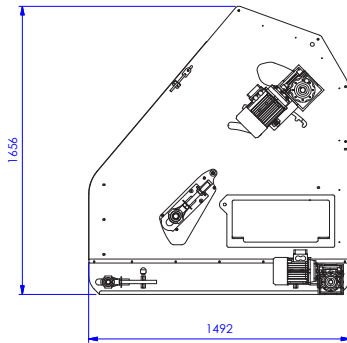
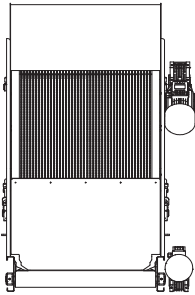
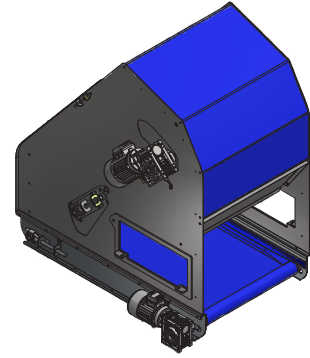
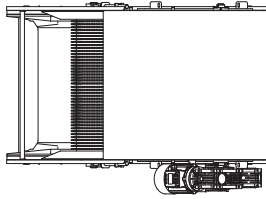
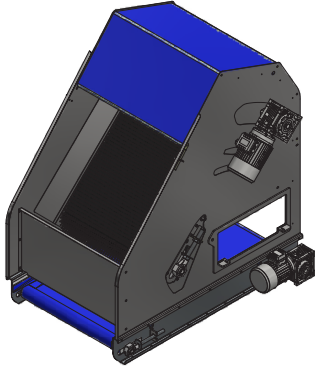

For discussion only!
 The dimensions are approximately.
 We are free to resize and change the machines,
 when we deem it necessary.

For principle: ISO 8015		General tolerances: ISO 20768		Fit system: ISO 286		Geometrical tolerancing: ISO 1101	
Project: Leaf separator							
Description: LS 80							
Surface:							
Engineer: JAJ		Scale: 1:20		00040282		Revision: 01	
Date: 23-5-2019		Sheet size: A3		Unit: mm		Sheet: 1 of 2	

LS 100

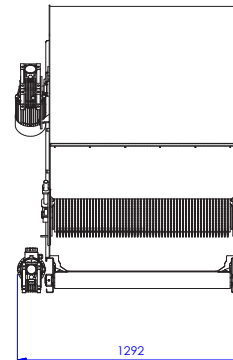
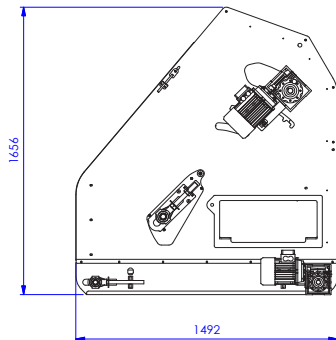
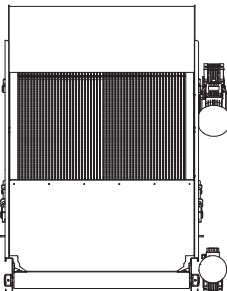
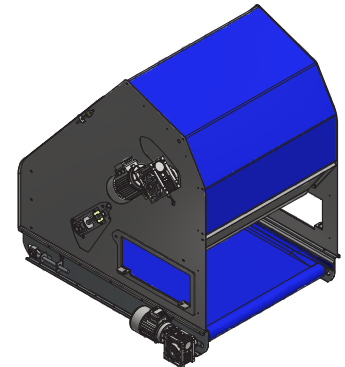
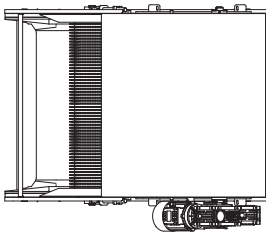
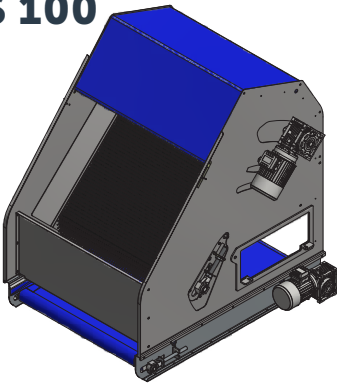



For discussion only!
 The dimensions are approximately.
 We are free to resize and change the machines,
 when we deem it necessary.

For principle: ISO 8015		General tolerances: ISO 20768		Fit system: ISO 286		Geometrical tolerancing: ISO 1101	
Project: Leaf separator							
Description: LS 100							
Surface:							
Engineer: SRP		Scale: 1:20		00016723		Revision: 01	
Date: 11-6-2019		Sheet size: A3		Unit: mm		Sheet: 1 of 2	

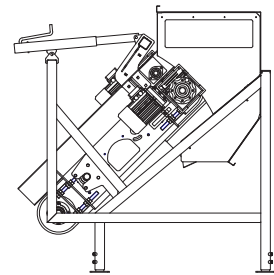
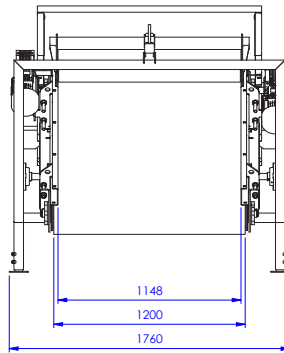
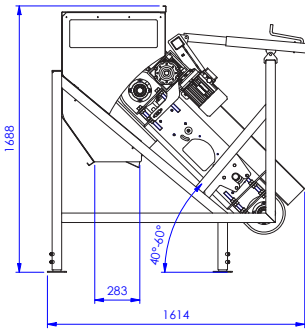
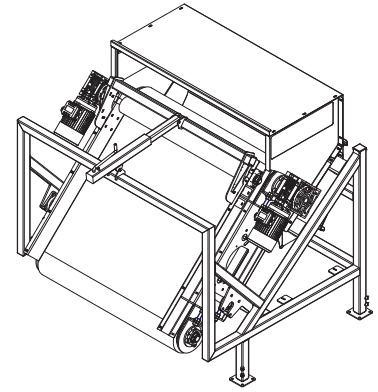
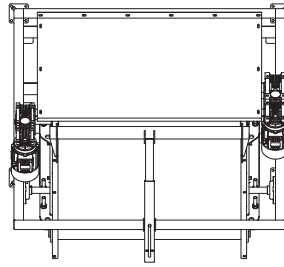
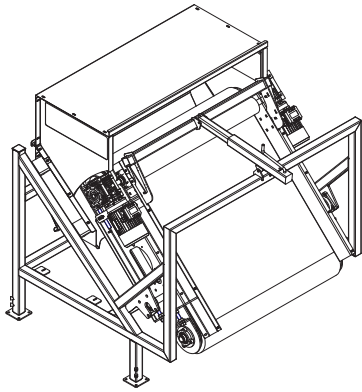
LS 120



For discussion only!
The dimensions are approximately.
We are free to resize and change the machines,
when we deem it necessary.

For principle: ISO 8015	General tolerances: ISO 20768	Fit system: ISO 286	Geometrical tolerancing: ISO 1101
	Project: Leaf separator - -		
Description: LS 120			
Surface: - - -			
	Engineer: SRPL	Scale: 1 : 22	00196873
Date: 31-5-2022	Sheet size: A3	Unit: mm	
Sheet: 1 of 3			Revision: 00