

SH 50-25-32 (with 1 side bulkhead)

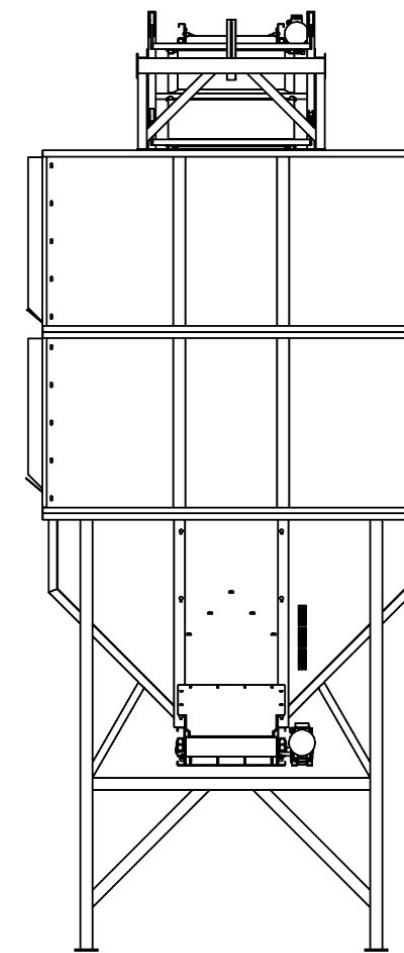

For discussion only!
 The dimensions are approximately.
 We are free to resize and change the machines,
 when we deem it necessary.

Tol principle: ISO 8015		General tolerances: ISO 20768		Fit system: ISO 286		Geometrical tolerancing: ISO 1101	
Project: Storage hopper		Description: SH 50-25-32 (with 1 side bulkhead)					
Surface:		Engineer: S.laan					
Date: 28-6-2019		Scale: 1 : 50		Sheet size: A3		00003476	
Unit: mm		Sheet: 1 of 2		Revision: 00			

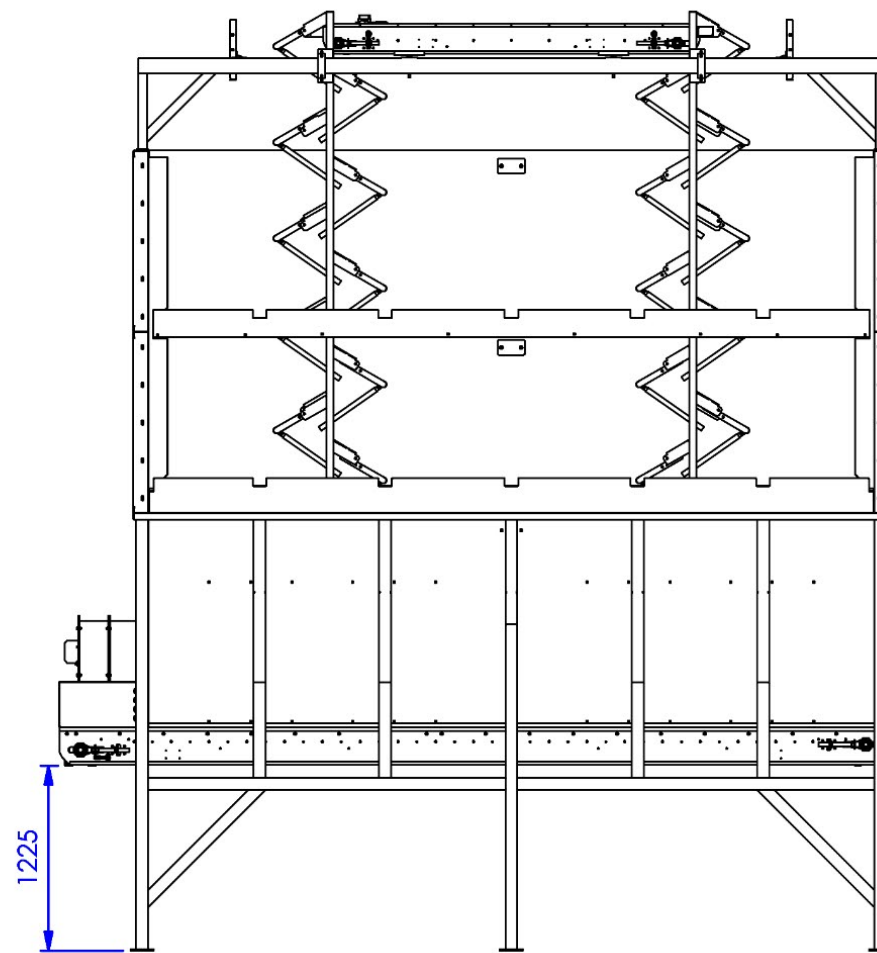
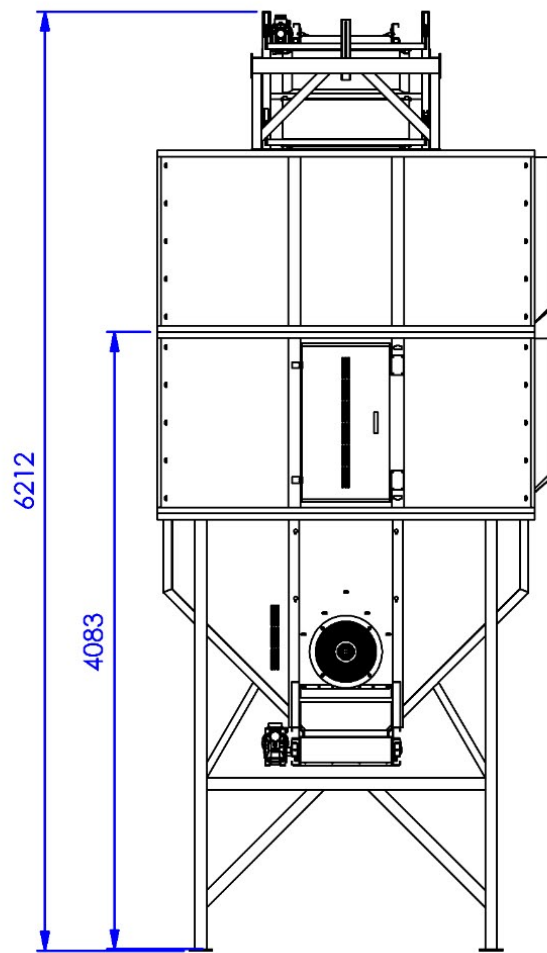
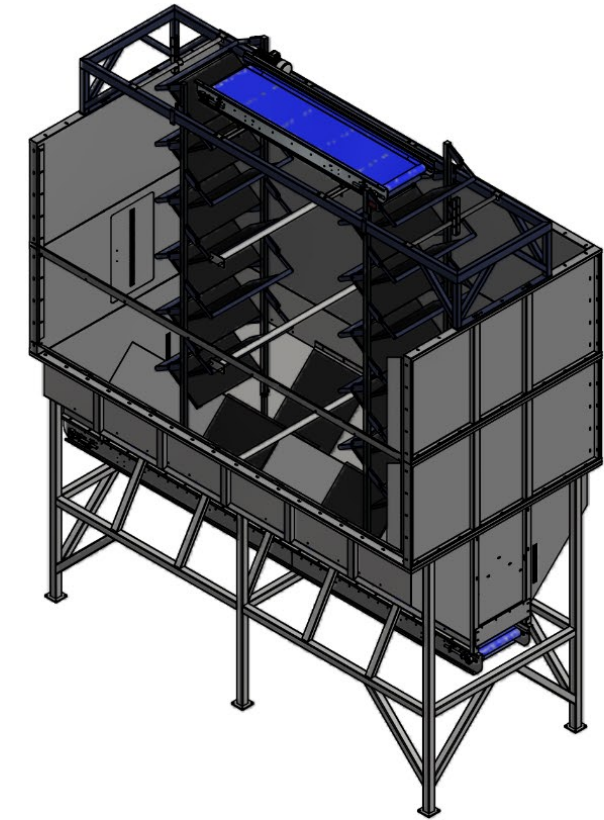
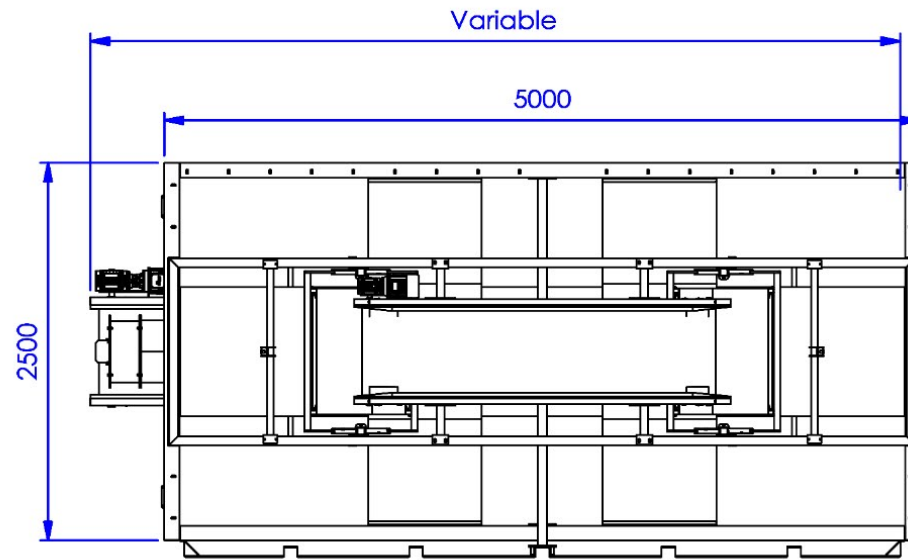
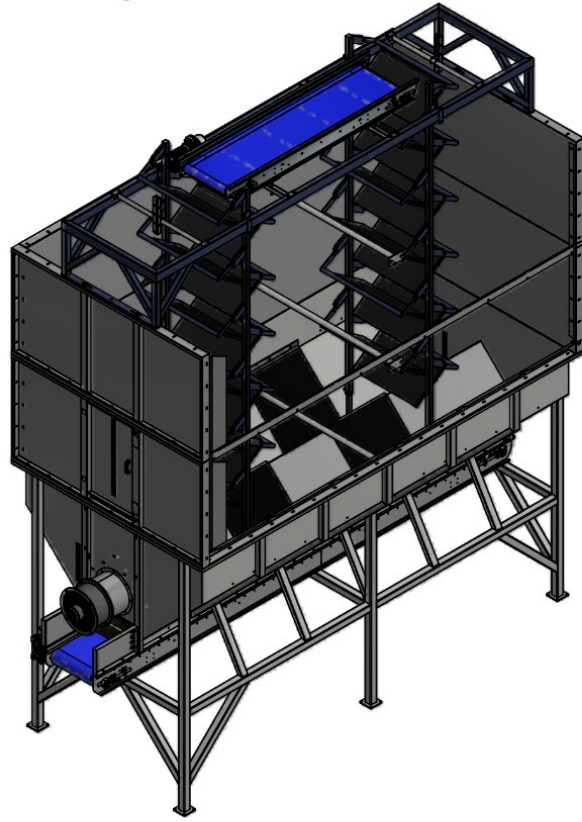